

# Processor / Power

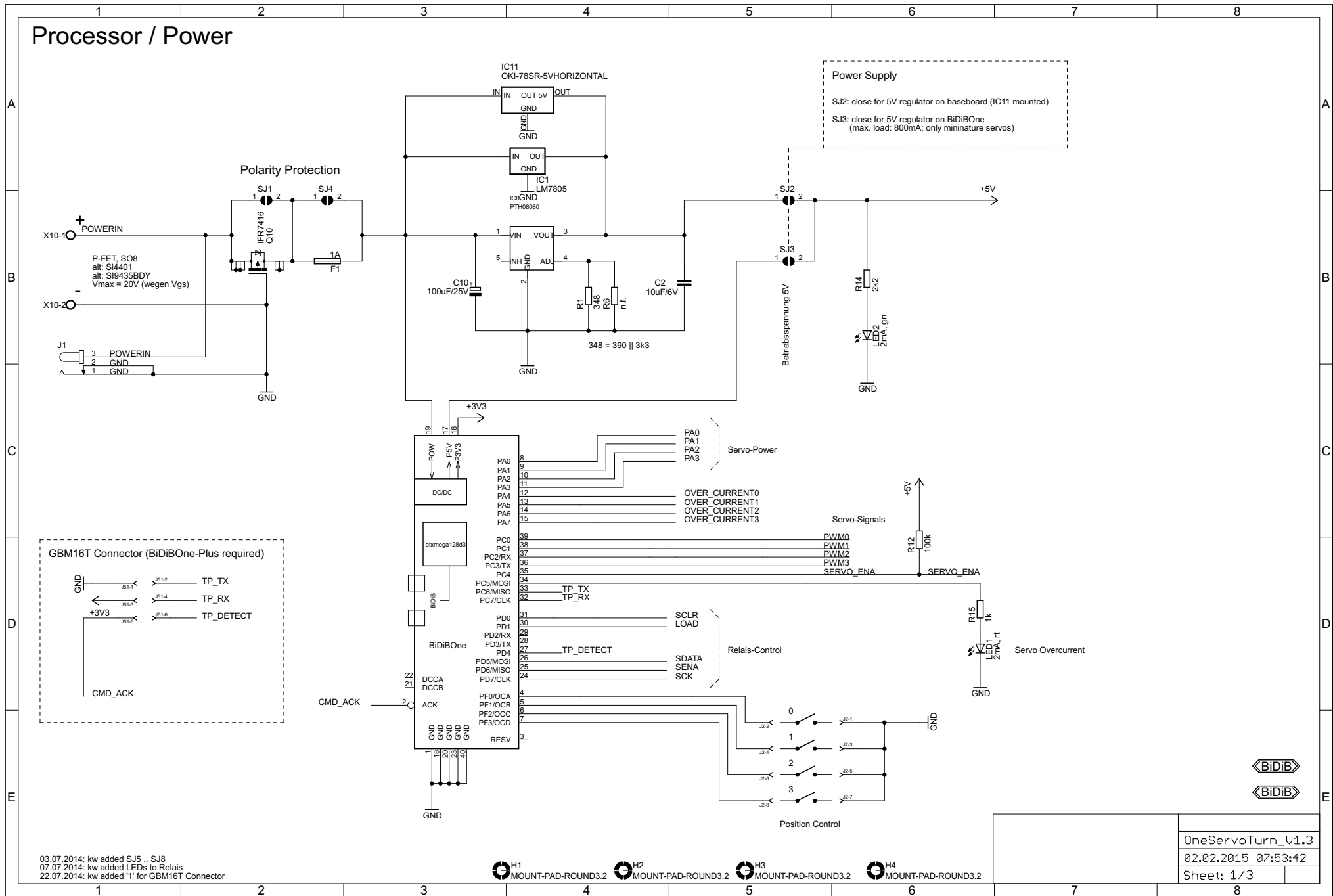

# Servo-Outputs

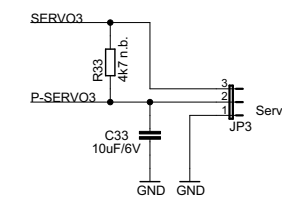
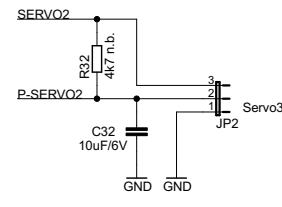
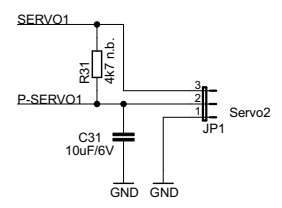
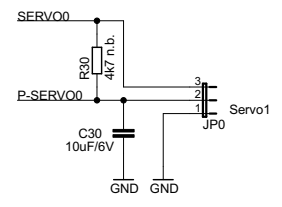
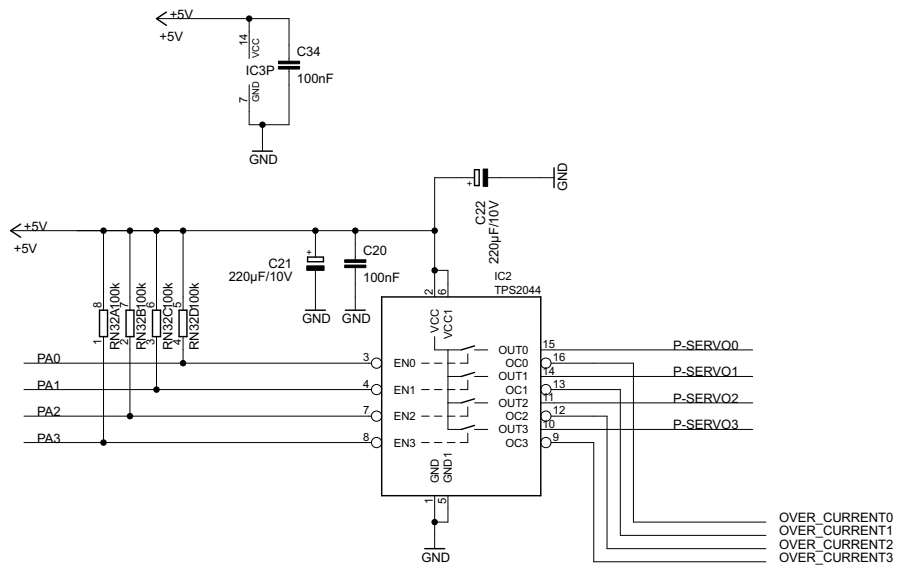
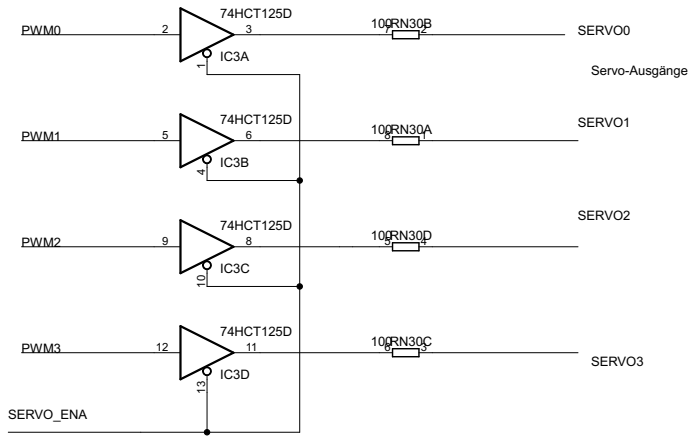

Entwicklung:  
Wolfgang Kufer  
Christoph Schörner  
www.opendcc.de  
www.fichtelbahn.de

OneServoTurn\_U1.3  
02.02.2015 07:53:42  
Sheet: 2/3

# Frog Polarity / Herzstückpolarisation

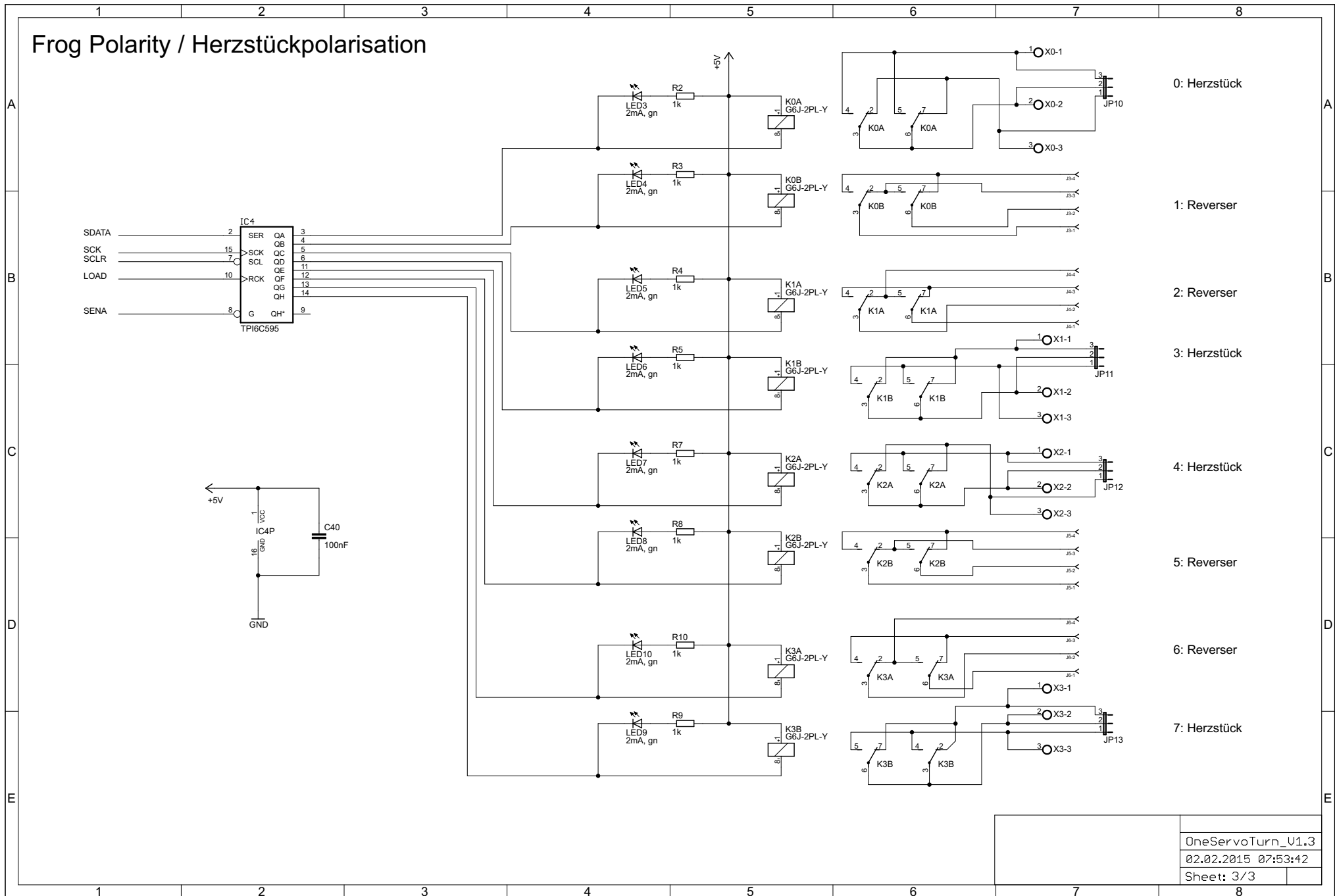

- 0: Herzstück
- 1: Reverser
- 2: Reverser
- 3: Herzstück
- 4: Herzstück
- 5: Reverser
- 6: Reverser
- 7: Herzstück